

| PROJECT | QUANTITY | ITEM NO |
|---------|----------|---------|
|---------|----------|---------|

SmartCombi™ combi oven

MODEL **ESC-620** electric
GSC-620 gas



SmartCombi ESC/GSC-620 with capacity of 6 full-size sheet pans on grids or 12 full-size steam table pans.



Easily access cooking data with USB port conveniently located at front of unit.

General Information

Henny Penny SmartCombi combi ovens use moist heat and dry heat, either separately or in combination, to produce the ideal cooking conditions for a wide variety of foods.

Four basic cooking modes employ a variety of built-in functions in different ways.

- Steaming/Moist heat: 86-266°F (30-130°C)
Low and high-temperature steaming.
- Convection cooking/Dry heat: 86-572°F (30-300°C)
Active humidity reduction
- Combination/Dry and moist heat: 86-482°F (30-250°C).
Individual or automatic humidity control between 0 and 100% RH.
- Rethermalizing/Dry and moist heat: 86-356°F (30-180°C)
Special fan speed function and banqueting programs.

Henny Penny bridges the gap between boiler and boilerless combis with patented Advanced Steam Technology.™ This system generates large amounts of steam in the cooking cabinet quickly without the delimiting and maintenance issues of a boiler.

Operator can select humidity levels from 0-100% relative humidity. Digital humidity control continuously measures and maintains the humidity level in the cabinet by automatically adding steam or venting excess humidity.

The SmartCombi features a wide range of pre-programmed menu selections for fully automatic cooking and can be easily programmed by the user. Units include multi-sensor core temperature probe for automatic probe cooking. USB port is standard.

Standard Features

- Patented Advanced Steam Technology™ for effective steam generation without boilers.
- ClimaSelect climate control allows operator to select any humidity level between 0% and 100%.
- ClimaMonitor automatically measures and maintains selected humidity level.
- Digital control panel features easy-to-read LED displays and icons.
- Manual or automatic cooking:
 - Create and save up to 99 9-step custom cooking programs.
 - Select food category from SmartMenu™ pictogram, then choose preset cooking program.
 - Select and/or change individual parameters during cooking.
- Simple CombiDial control: rotate to select, push to confirm and start.
- Temperature displayed in °F or °C.
- Choose language for operations and service diagnostics programs.
- Auto-reverse fan for fast, even cooking throughout the cabinet.
- Variable fan speed function for high quality baking, rethermalizing and banquet cooking.
- Delayed start and preheat/cool down button.
- USB port enables simple download of programs, diagnostic messages or HACCP data.
- Filterless grease extraction.
- Retractable spray hose for quick, easy rinsing of interior.
- WaveClean™ self-cleaning system significantly reduces water and detergent consumption.
- Interior cabinet of corrosion resistant chrome-nickel stainless steel.
- Exterior made from 1 mm chrome-nickel stainless steel.
- Full perimeter door seal.
- Energy efficient triple-pane glass.

Options, accessories*

- Stands and cabinets
- Stacking kit
- Chicken grids
- Mobile oven racks, cart, rail insert
- Two-stage safety door lock
- HACCP printer
- Alternate voltages
- Marine version

*See separate accessories data sheets for details

| | | |
|-----------------------------------|--|-----------------------------------|
| <input type="checkbox"/> APPROVED | <input type="checkbox"/> APPROVED AS NOTED | <input type="checkbox"/> RESUBMIT |
| AUTHORIZED SIGNATURE | | DATE |



SmartCombi™ combi oven

MODEL **ESC-620** electric
GSC-620 gas

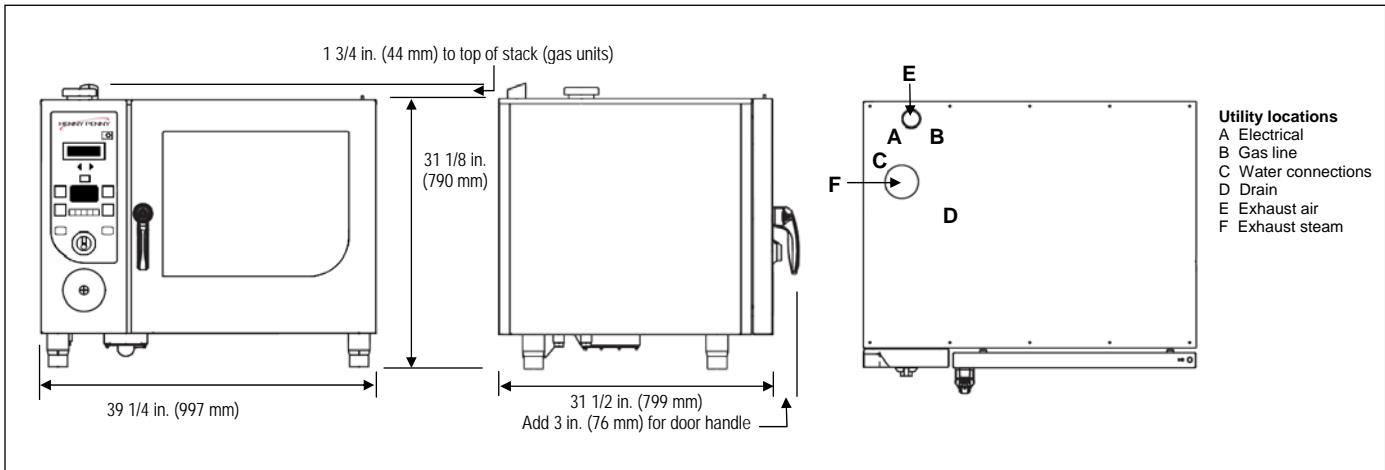

Dimensions

Height: 31 1/8 in. (790 mm)
Width: 39 1/4 in. (997 mm)
Depth: 31 1/2 in. (799 mm)

Required Clearances

Left: 20 in. (500 mm) service access:
Right: 2 in. (50 mm) air flow
Back: 2 in. (50 mm) air flow, utility connections:
Front: 28 in. (700 mm) door open

Crated dimensions

Length: 42 1/2 in. (1080 mm)
Depth: 37 7/8 in. (962 mm)
Height: 40 1/4 in. (1022 mm)
Volume: 37.5 cu. ft. (1.06 m³)

Net weight: 310 lbs. (140 kg)

Crated weight: 375 lbs. (170 kg)

Heating

Electric Connected load: 22.4 kW
Gas Output: 58000 BTU/hr
Connection: R 3/4" NPT external thread

Water connections

3/4 in. standard cold water connection
3/4 in. soft water connection
2 in. (50 mm) drain

Pan capacity

- 6 full-size sheet pans 18 x 26 (460 x 660 mm) lengthwise on grids.
- 12 full-size steam table pans 2 1/2 in. (65 mm), two per rack crosswise.
- 4 standard 6-chicken grids lengthwise, 24 chickens per load

Electrical

| Volts | Phase | Cycle/Hz | Watts | Amps | Wire |
|-------|-------|----------|-------|-----------|------|
| 208 | 3 | 60 | 17600 | 47.5-52.4 | 3+G |
| 240 | 3 | 60 | 17600 | 41.2-46.0 | 3+G |
| 400 | 3 | 50/60 | 17600 | 31.0 | 3NG |
| 440 | 3 | 60 | 17600 | 22.5-24.3 | 3+G |
| 480 | 3 | 60 | 17600 | 20.6-22.4 | 3+G |

Gas models

| | | | | | |
|-----|---|----|-----|-----|-----|
| 120 | 1 | 60 | 800 | N/A | 1NG |
| 230 | 1 | 50 | 800 | N/A | 1NG |

Laboratory certifications



Utility locations

A Electrical
B Gas line
C Water connections
D Drain
E Exhaust air
F Exhaust steam

Bidding Specifications

- Provide Henny Penny SmartCombi combi oven, model ESC-620 electric or GSC-620 gas. Units are designed to cook with moist heat (gentle or regular steaming), dry heat (convection cooking) or a combination of these cooking modes.
- Unit shall operate with boilerless Advanced Steam Technology.™
- Unit shall have 0-100% humidity control within the cooking chamber.
- Unit shall be programmable using SmartMenu icon-based navigation and LED display that provides optimal viewing of programs, time, temperature and other data.
- Unit shall be equipped with a variable speed, auto reverse fan that moves air in alternating directions for more even heating.
- Unit shall have AutoShower integrated flushing function.
- Unit shall have WaveClean automatic self-cleaning system, standard.
- Unit shall have seamless stainless steel cooking chamber, full-perimeter door seal and triple-pane glass for energy efficiency.
- Unit shall have a maximum operating temperature of 572°F (300°C) if electric and 482°F (250°C) if gas.
- Unit shall accommodate up to 6 full-size sheet pans 18 x 26 in. (460 x 660 mm) or 12 steam table pans, 2 1/2 in. deep. Tile-resistant rack insert shall be of stainless-steel.
- Unit shall have a condensate drip pan with central direct drain.

Continuing product improvement may subject specifications to change without notice.

Henny Penny Corporation
PO Box 60 Eaton OH 45320 USA

+1 937 456.8400 800 417.8417
+1 937 456.8434 Fax 800 417.8434 Fax

www.hennypenny.com

HENNY PENNY