

PROJECT	QUANTITY	ITEM NO
---------	----------	---------

Auto lift open fryers



MODEL **OEA-322** 2-well electric
OGA-322 2-well gas



Two-well auto lift open fryer, model OEA-322

General Information

Henny Penny auto lift open fryers offer high-volume, integral multi-well frying with auto lift capabilities. Auto lift open fryers automatically raise loads out of the fry pot when cooking program is complete. This feature promotes perfect results without constant monitoring and can significantly increase productivity in lightly staffed operations.

The quiet, dependable auto lift mechanism is designed into the high-quality, high-efficiency Henny Penny 320 Series open fryer without adding one square inch to the footprint.

Henny Penny's unique heat-exchange design produces extremely fast temperature recovery—typically in seconds—while requiring less than 2 kW per gallon of oil or shortening. That level of efficiency has earned the Henny Penny 320 series open fryer the ENERGY STAR® mark.

Built-in filtration system filters hot frying oil in under 4 minutes, with no separate pumps or pans required. Hot filtered oil returns directly to each well. Quick, easy and frequent filtering extends shortening life and can result in significant savings in time and direct shortening costs.

The OEA/OGA-322 auto lift open fryer features two integral fry wells with two lifters at each well for full or half-basket loads. Henny Penny's heavy-duty stainless steel rectangular fry pots promote fast even cooking and come with a 7-year warranty—the best in the business.

The standard **COMPUTRON™ 8000** controller provides fully automatic, programmable operation, as well as energy-saving, filtration and load management features.

Standard Features

- Stainless steel construction for easy-cleaning and long life.
- 2 heavy-duty stainless steel rectangular fry pots with 7 year warranty.
- **COMPUTRON™ 8000** control with
 - 10 programmable cook cycles per well
 - Melt mode
 - Idle mode
 - Load compensation
 - Proportional control
 - Optional filter prompt and customizable filter tracking
 - Clean-out mode.
 - 16-character digital display with multiple language settings.
- Each well can be programmed to operate half baskets independently or together at the touch of a button.
- Built-in filtration with stainless steel **Max** filtering screen and filter envelope.
- Rugged direct drive lift mechanism powered by quiet, low-voltage motor.
- Motor and drive built into existing cabinet—footprint is NOT increased.
- Easy basket set and release.
- Specially designed cold zone prevents scorching.
- 4 heavy-duty casters, 2 locking.

Accessories shipped with unit

- Fry baskets—please select one
 - 2 full baskets
 - 1 full and 2 half baskets
 - 4 half baskets
- 2 basket supports
- **Max** shortening filtration system and 2 PHT filter envelopes.

Accessories and options available separately

- Shortening shuttle
- Filter rinse hose
- Fry well covers

<input type="checkbox"/> APPROVED	<input type="checkbox"/> APPROVED AS NOTED	<input type="checkbox"/> RESUBMIT
AUTHORIZED SIGNATURE		DATE



Henny Penny Corporation
 PO Box 60 Eaton OH 45320 USA
 +1 937 456.8400 800 417.8417
 +1 937 456.8434 Fax 800 417.8434 Fax
www.hennypenny.com

Auto lift open fryers

MODEL **OEA-322** 2-well electric
OGA-322 2-well gas

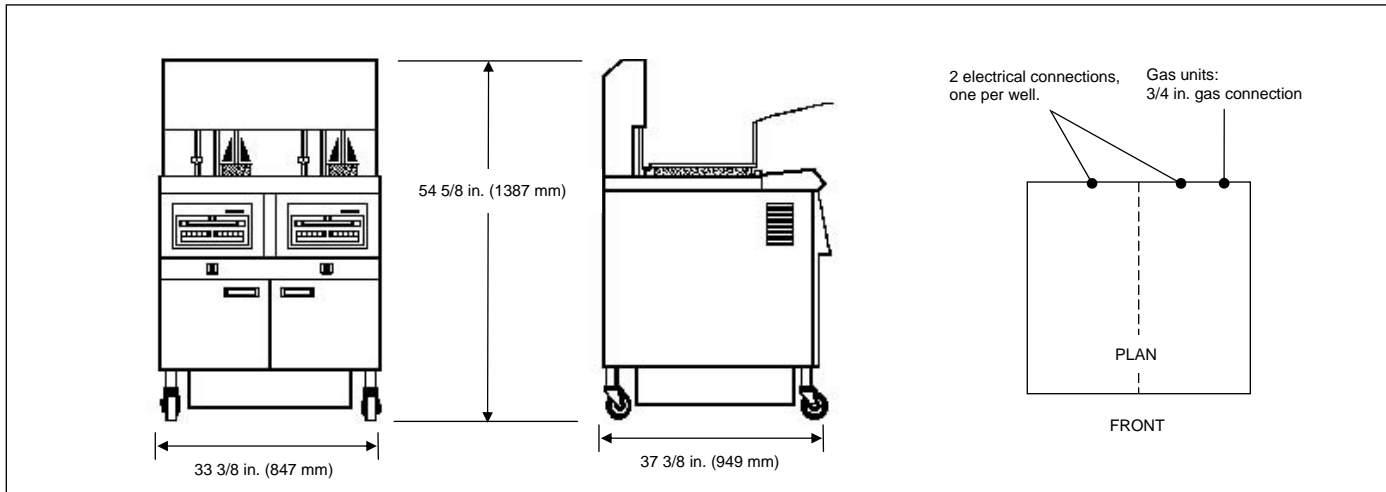

Dimensions

Width 33 3/8 in. (847 mm)
Depth 37 3/8 in. (949 mm)
Height 54 5/8 in. (1387 mm)

Required clearances

Sides: 6 in. (152 mm) air flow
Back: 6 in. (152 mm) air flow, connections
Front: 30 in. (762 mm) filter pan removal

Crated dimensions

Length 40 in. (1016 mm)
Depth 39 in. (991 mm)
Height 65 in. (1651 mm)
Volume 58.7 cu. ft. (1.66 m³)

Net weight N/A

Crated weight

Electric 469 lbs. (213 kg)
Gas 529 lbs. (240 kg)

Heating

Electric Immersed elements, 14.4 kW per vat
Gas Natural or liquid petroleum
2 burners, 85,000 BTU/hr (25 kW) per vat
3/4 in. connection

Oil capacity:

32 qts. or 65 lbs. (30 liters or 30 kg) per vat

Electrical

Volts	Phase	Cycle/Hz	Watts per well	Amps per well	Wire
208	3	60	14400	39.9	3+G
220-240	3	50/60	14400	37.2	3+G
240	3	60	14400	37.2	3+G
400	3	50/60	14400	21.7	3NG
480	3	60	14400	17.5	3+G

Two electrical connections required, one for each well. Power cord and plug must be installed on site by a qualified electrician.

Gas models

120	1	60	N/A	12.0	2+G
230	1	50	N/A	2.5	1NG

Laboratory certifications



Bidding Specifications

- Provide Henny Penny model OEA-322 two-well electric open fryer or model OGA-322 two-well gas open fryer with auto-lift feature, **COMPUTRON™ 8000** control, and built-in filtration system standard.
- Materials—cabinet, deck, exhaust stack, filter drain pan and various fittings are stainless steel. Fry pots are heavy duty stainless steel.
- Unit shall incorporate high-efficiency heat-exchange design for extremely fast recovery.
- Unit qualifies for the ENERGY STAR® mark.
- Heating elements encircle the fry pot part-way up the side, and are not located at the bottom or below the pot. This design produces a "cold zone" that extends oil life.
- Unit shall have 2 auto lift mechanisms per well and timers to accommodate half-basket operation.
- Unit's controller provides for programmable or manual operation with press-key controls and LED digital display. Control offers idle and melt modes, load compensation, filtration tracking and 7-day history.
- Unit shall include 4 heavy-duty casters, 2 locking.
- Unit ships with stainless steel **Max** filtration screen and 2 PHT filter envelopes, 2 full baskets, 1 full basket and 2 half baskets, or 4 half baskets.

Continuing product improvement may subject specifications to change without notice.

HENNY PENNY
Global Foodservice Solutions

www.hennypenny.com