

PROJECT	QUANTITY	ITEM NO
---------	----------	---------

Large capacity open fryers

With auto lift

MODEL **OEA-341** electric
OGA-341 gas



Large capacity auto lift open fryer, model OEA-341, shown with skim basket.

General Information

The 340 series large capacity open fryers from Henny Penny are designed to offer maximum frying surface area within a reasonable footprint. These high volume open fryers feature a larger, shallower fry vat that produces more consistent frying results with items that float when cooking.

The quiet, dependable auto lift mechanism is designed into the large-capacity 340 series open fryer without adding one square inch to the footprint.

Henny Penny's unique high-efficiency heat-exchange design produces extremely fast temperature recovery—typically in seconds—without requiring excess oil to retain heat. Fast recovery speeds up production, saves energy, and preserves frying oil quality by

reducing temperature fluctuations.

Built-in filtration system filters hot frying oil in under 4 minutes, with no separate pumps or pans required. Hot filtered oil returns directly to the fry well. Quick, easy and frequent filtering extends shortening life and can result in significant savings in time and direct shortening costs.

The OEA/OGA-341 auto lift open fryer features two lifters for half or full-basket loads. Henny Penny's heavy-duty stainless steel rectangular fry pot promotes fast, even cooking and comes with a 7-year warranty—the best in the business.

The standard **COMPUTRON™ 8000** controller provides fully automatic, programmable operation, as well as energy-saving, filtration and load management features.

Standard Features

- Stainless steel construction for easy-cleaning and long life.
- Heavy-duty stainless steel rectangular fry pot with 7-year warranty.
- Large fry vat offers greater surface area and promotes more even cooking.
- Specially designed “beach” accommodates oil displacement when lowering basket.
- Rugged direct-drive lift mechanism with quiet, low-voltage motor.
- Motor and drive built into existing cabinet—footprint is NOT increased.
- Built-in filtration with over-the-top return to wash away remnants.

- **COMPUTRON™ 8000** control with
 - 10 programmable cook cycles
 - Melt mode
 - Idle mode
 - Load compensation
 - Proportional control
 - Optional filter prompt and customizable filter tracking
 - Clean-out mode.
 - 16-character digital display with multiple language settings.
- Fryer can be programmed to operate half baskets independently or together at the touch of a button.
- Easy basket set and release.
- Specially designed cold zone prevents scorching.
- 4 heavy-duty casters, 2 locking.

Accessories shipped with unit

- Fry baskets—please select one
 - 1 full basket
 - 2 half baskets
- Basket support
- Lift tool for basket support
- Lift tool for electric elements
- **Max** shortening filtration system and 2 PHT filter envelopes.

Accessories and options available separately

- 3 third-size fry baskets per well
- Shortening shuttle
- Filter rinse hose

<input type="checkbox"/> APPROVED	<input type="checkbox"/> APPROVED AS NOTED	<input type="checkbox"/> RESUBMIT
AUTHORIZED SIGNATURE		DATE



Henny Penny Corporation
PO Box 60 Eaton OH 45320 USA
+1 937 456.8400 800 417.8417
+1 937 456.8434 Fax 800 417.8434 Fax
www.hennypenny.com

PROJECT

ITEM NO

Large capacity open fryers

With auto lift

MODEL **OEA-341** electric
OGA-341 gas

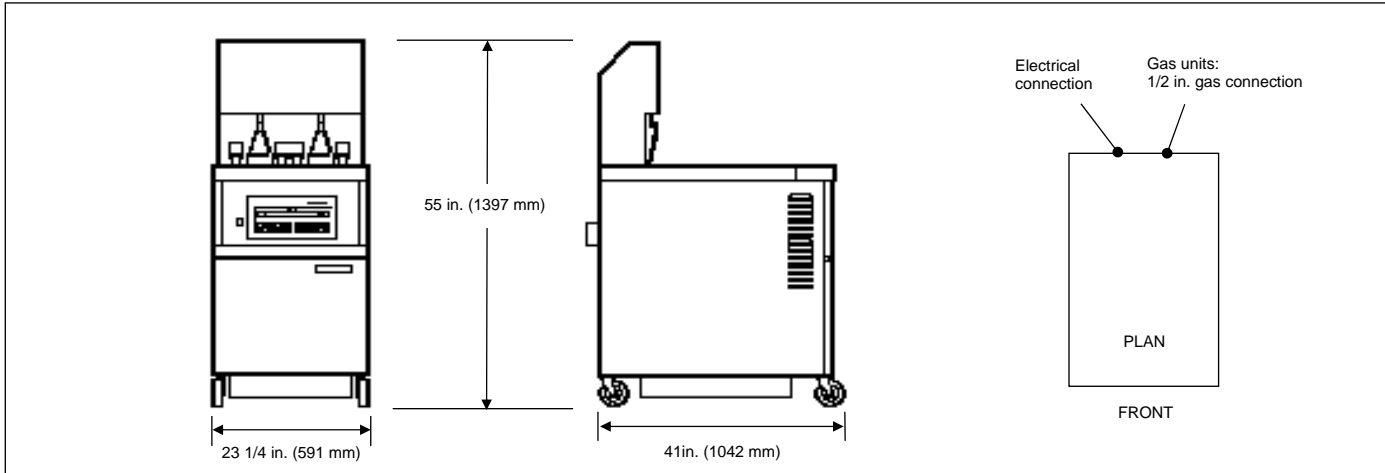

Dimensions

Width 23 1/4 in. (591 mm)
Depth 41 in. (1042 mm)
Height 55 in. (1397 mm)

Required clearances

Sides: 6 in. (152 mm) air flow
Back: 6 in. (152 mm) air flow, connections
Front: 30 in. (762 mm) filter pan removal

Crated dimensions

Length 46 in. (1169 mm)
Depth 30 in. (762 mm)
Height 65 1/2 in. (1664 mm)
Volume 52.3 cu. ft. (1.48 m³)

Net weight N/A

Crated weight

Electric 381 lbs. (173 kg)
Gas 413 lbs. (188 kg)

Heating

Electric Immersed elements, 22.0 kW
Gas Natural or liquid petroleum
3 burners, 120,000 BTU/hr (35 kW)
1/2 in. connection

Oil capacity

Electric 40 qts. or 80 lbs. (37.8 l or 36 kg)
Gas 45 qts. or 90 lbs. (42.5 l or 41 kg)

Electrical

Volts	Phase	Cycle/Hz	Watts	Amps	Wire
208	3	60	22000	61.0	3+G
240	3	60	22000	52.9	3+G
380-415	3	50	22000	32.5	3NG
480	3	60	22000	26.5	3+G

Power cord and plug must be installed on site by a qualified electrician.

Gas models

120	1	60	N/A	12.0	2+G
230	1	50	N/A	6.2	1NG

Laboratory certifications



Bidding Specifications

- Provide Henny Penny large capacity open fryer, model OEA-341 electric or model OGA-341 gas, with auto-lift feature, **COMPUTRON™ 8000** control, and built-in filtration system standard.
- Materials—cabinet, deck, exhaust stack, filter drain pan and various fittings are stainless steel. Fry pot is heavy duty stainless steel.
- Unit shall incorporate high-efficiency heat-exchange design for extremely fast recovery.
- Frying well is designed for large surface frying area and incorporates a flat rim to accommodate oil displacement from load.
- Heating elements encircle the fry pot part-way up the side, and are not located at the bottom or below the pot. This design produces a "cold zone" that extends oil life.
- Unit shall have two auto lift mechanisms and timers to accommodate half-basket operation.
- Unit's controller provides for programmable or manual operation with press-key controls and LED digital display. Control offers idle and melt modes, load compensation, filtration tracking and 7-day history.
- Unit shall include 4 heavy-duty casters, 2 locking.
- Unit ships with stainless steel **Max** filtration screen and 2 PHT filter envelopes, lifting tools for basket support and electric elements, and choice of 1 full fry basket or 2 half baskets.

Continuing product improvement may subject specifications to change without notice.

HENNY PENNY
Global Foodservice Solutions

www.hennypenny.com