

PROJECT	QUANTITY	ITEM NO
---------	----------	---------

High volume open fryers

MODEL **OFE-291** electric



High volume 8-head electric open fryer, model OFE-291.

General Information

The Henny Penny OFE-291 gives you high-volume frying from a single, compact footprint. In fact, it is the only single well open fryer available that can cook up to 21 lbs. (9.5 kg) of food per load. Large loads combined with programmable operation and available built-in filtration offer significant savings in time, labor, shortening, energy use and maintenance over the equivalent combination of smaller competitive fryers.

Henny Penny high-volume open fryers incorporate several beneficial design features, including rectangular fry pot, cold-zone, counter-balanced lid lift system, raised edge on fryer deck and more.

Henny Penny's unique high-efficiency heat-exchange design produces extremely fast temperature

recovery—typically in seconds—without requiring excess oil to retain heat. Fast recovery speeds up production, saves energy, and preserves frying oil quality by reducing temperature fluctuations.

Built-in filtration system filters hot frying oil in minutes, with no separate pumps or pans required. Hot filtered oil returns directly to the fry well.

COMPUTRON™ 8000 control provides fully automatic, programmable operation, as well as energy-saving, filtration and load management features.

Henny Penny's heavy-duty stainless steel rectangular fry pot promotes fast, even cooking and comes with a 7-year warranty—the best in the business.

Standard Features

- Stainless steel cabinet for easy-cleaning and long life.
- Heavy-duty stainless steel rectangular fry pot with 7-year warranty.
- Fully insulated fry pot.
- High-efficiency heating elements.
- Patented heat transfer technology recovers quickly with up to eight head of chicken per load in only 100 lbs. (45.4 kg) frying oil.
- Patented counter-balanced lid lift for easy loading and unloading.
- Built-in filtration.
- Space-saving design requires only about seven square feet (.67 m²) of floor space.

- Raised edge on deck reduces spills.
- 4 heavy-duty casters, 2 locking.
- **COMPUTRON™ 8000** control
 - 10 programmable cook cycles
 - Melt mode
 - Idle mode
 - load compensation
 - Proportional control
 - Optional filter prompt and customizable filter tracking
 - Clean-out mode
 - 16-character digital display with multiple language settings

Accessories shipped with unit

- Loading carrier
- Basket configuration, choose one:
 - Full basket—4 flat wire baskets, 1 wire rack cover, rack handle
 - Half-size rack—4 wire racks, 1 wire rack cover, rack handle
- Stirrer and drain clean-out rod
- **Max** shortening filtration system and 2 PHT filter envelopes. (Units available without filtration.)

Accessories and options available separately

- Direct Connect shortening disposal (filtration equipped units, only)
- Shortening shuttle
- Filter rinse hose
- Filter pan dolly

<input type="checkbox"/> APPROVED	<input type="checkbox"/> APPROVED AS NOTED	<input type="checkbox"/> RESUBMIT
AUTHORIZED SIGNATURE		DATE



Henny Penny Corporation
 PO Box 60 Eaton OH 45320 USA
 +1 937 456.8400 800 417.8417
 +1 937 456.8434 Fax 800 417.8434 Fax
www.hennypenny.com

High volume open fryers

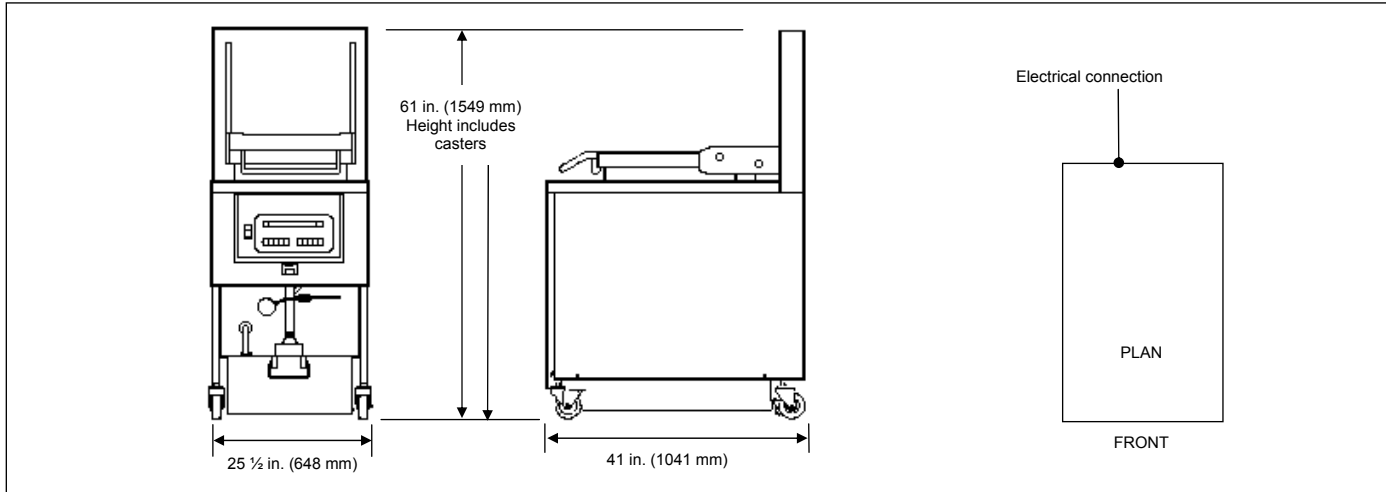
MODEL **OFE-291** electric

Dimensions

Width 25 ½ in. (648 mm)
 Depth 41 in. (1041 mm)
 Height 61 in. (1549 mm)

Required clearances

Sides: 6 in. (152 mm) air flow
 Back: 6 in. (152 mm) air flow
 Front: 38 in. (965 mm) filter pan removal

Crated dimensions

Length: 46 in. (1168 mm)
 Depth: 30 in. (762 mm)
 Height: 70 in. (1778 mm)
 Volume: 56 cu. ft. (1.58 m³)

Net weight N/A

Crated weight

Electric 755 lbs. (343 kg)

Heat

4 immersed elements 4250W each
 (17000W total)

Capacity

Product: 21 lbs. (9.5 kg) 8-head chicken
 Oil: 100 lbs. (46.6 l)

Electrical

Volts	Phase	Cycle/Hz	Watts	Amps	Wire
208	3	60	17000	47.2	3+G
240	3	60	17000	40.9	3+G
480	3	60	17000	20.5	3+G

Power cord and plug must be installed on site by a qualified electrician.

Laboratory certifications



Bidding Specifications

- Provide Henny Penny high volume open fryer, model OFE-291 electric, 21 lbs. (9.5 kg) 8-head chicken capacity per load, with **COMPUTRON™ 8000** control and built-in filtration system.
- Materials—cabinet, deck, exhaust stack, filter drain pan and various fittings are stainless steel. Lid lift system and fry pot are heavy duty stainless steel.
- Units shall incorporate high-efficiency heat-exchange design for extremely fast recovery.
- Counter-balanced lid lift system enables easy loading and unloading.
- Heating elements encircle the fry pot part-way up the side, and are not located at the bottom or below the pot. This design produces a “cold zone” that extends oil life.
- Unit’s controller provides for programmable or manual operation with press-key controls and LED digital display. Control offers idle and melt modes, load compensation, filtration tracking and 7-day history.
- Units will include 4 heavy-duty casters, 2 locking.
- Units with filtration system ship with stainless steel **Max** filtration screen and 2 PHT filter envelopes. All units ship with loading, rack, basket handles and choice of fry baskets or wire racks.

Continuing product improvement may subject specifications to change without notice.

HENNY PENNY
 Global Foodservice Solutions

www.hennypenny.com