

PROJECT	QUANTITY	ITEM NO
---------	----------	---------

High volume pressure fryers

MODEL **PFG-691** Gas



PFG-691 high volume 8-head gas pressure fryer

General Information

Henny Penny first introduced commercial pressure frying to the foodservice industry 50 years ago. Today, Henny Penny pressure fryers continue to lead the industry in performance, durability and innovation.

Frying under pressure enables lower cooking temperatures and faster cooking times. Pressure also helps seal in the food's natural juices and reduce absorption of frying oil into product. Results of pressure frying generally produce a product with less fat and more original flavor than other methods of frying.

The Henny Penny PFG-691 is the only gas pressure fryer on the market that cooks up to 8 head of chicken or 24 lbs. (11 kg) of food in a single load. A high volume fryer can offer significant savings in time, labor, frying oil, energy use and

maintenance over an equivalent combination of smaller competitive fryers.

Henny Penny high-volume pressure fryers incorporate several beneficial design features, including rectangular fry pot, cold-zone, counter-balanced lid lift and lock, raised edge on fryer deck and more.

The PFG-691 features a high-efficiency burner system with solid-state ignition. Average temperature of exhaust gases are among the lowest in the industry. **COMPUTRON™ 8000** control provides fully automatic, programmable operation, as well as energy-saving, filtration and load management features.

Available built-in filtration is standard and can be accomplished in minutes with no handling of hot oil.

Standard Features

- Stainless steel cabinet for easy-cleaning and long life.
- Heavy-duty stainless steel rectangular fry pot with 7-year warranty.
- Fully insulated fry pot.
- High-efficiency burners.
- Patented draft-induced heat transfer technology.
- Patented counter-balanced lid lift and lock system for easy loading and unloading.
- Fry pot protection system.
- Built-in filtration.
- Raised edge on deck reduces spills.
- 4 heavy-duty casters, 2 locking.

- **COMPUTRON™ 8000** control
 - 10 programmable cook cycles
 - Melt mode
 - Idle mode
 - load compensation
 - Proportional control
 - Optional filter prompt and customizable filter tracking
 - Clean-out mode
 - 16-character digital display with multiple language settings

Accessories shipped with unit

- Loading carrier
- Basket configuration, choose one:
 - Full basket—4 flat wire baskets, 1 wire rack cover, rack handle
 - Half-size rack—4 wire racks, 1 wire rack cover, rack handle
- Stirrer and drain clean-out rod
- **Max** shortening filtration system and 2 PHT filter envelopes. (Units available without filtration.)

Accessories and options available separately

- Direct Connect shortening disposal (filtration equipped units, only)
- Shortening shuttle
- Filter rinse hose
- Filter pan dolly

<input type="checkbox"/> APPROVED	<input type="checkbox"/> APPROVED AS NOTED	<input type="checkbox"/> RESUBMIT
AUTHORIZED SIGNATURE		DATE



PROJECT	ITEM NO
---------	---------

High volume pressure fryers

MODEL **PFG-691** Gas

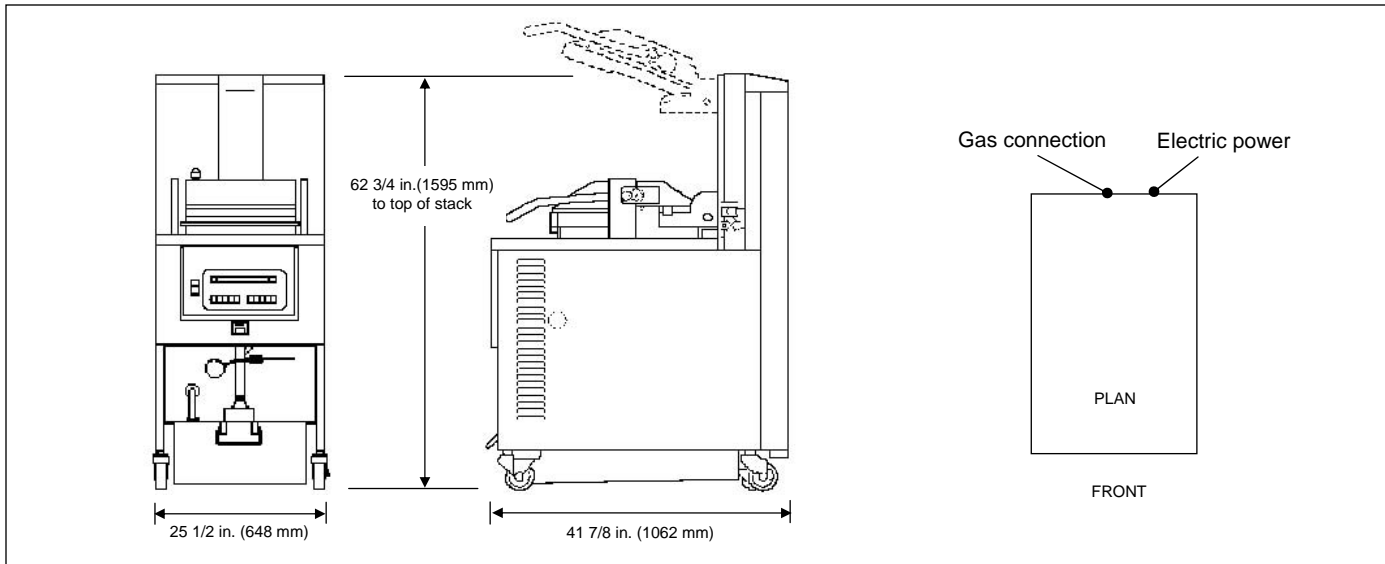

Dimensions

Height: 62 3/4 in. (1595 mm)
 Width: 25 1/2 in. (648 mm)
 Depth: 41 7/8 in. (1062 mm)

Required clearances

Top: 7 in. (178 mm) lid up for cleaning
 Sides: 6 in. (152 mm) air flow
 Back: 6 in. (152 mm) air flow
 Front: 38 in. (965 mm) filter pan removal

Crated dimensions

Length: 46 in. (1168 mm)
 Depth: 30 in. (762 mm)
 Height: 70 in. (1778 mm)
 Volume: 56 cu. ft. (1.58 m³)

Net weight

N/A

Crated weight 935 lbs. (424.5 kg)

Pressure

Operating pressure: 12 psi.
 Safety valve setting: 14.5 psi.

Heat

Natural or liquid petroleum gas
 4 burners
 1 3/4 in. connection
 100,000 BTU/hr (29 kW)

Capacity

Product: 24 lbs. (10.9 kg) 8-head chicken
 Oil: 100 lbs. (46.6 l)

Electrical

Volts	Phase	Cycle/Hz	Watts	Amps	Wire
100	1	50/60	1200	12.0	2+G
120	1	60	1200	10.0	2+G
220-240	1	50/60	1200	6.0	2+G
230	1	50	1200	2.5	1NG

Optional power cord and plug can be supplied for 120V units, only.

Plug type: 2-pole, 3-wire NEMA 5-15 P



Laboratory certifications



Bidding Specifications

- Provide Henny Penny Model PFG-691 high-volume gas pressure fryer, 24 lbs. (10.9 kg) 8-head chicken capacity per load, with **COMPUTRON™ 8000** control and built-in filtration system.
- Materials—cabinet, deck, exhaust stack, filter drain pan and various fittings are stainless steel. Lid lift and lock system is heavy-duty stainless steel. Fry pot is heavy duty stainless steel.
- Units shall incorporate high-efficiency heat-

exchange design for extremely fast recovery.

- Counter-balanced lid lift system enables easy loading and unloading. Lid remains in locked position until pressure reaches 1 psi.
- Gas burners encircle pot part-way up the side, and are not located below pot. This design produces a “cold zone” that extends suitable oil life.
- Unit’s controller provides for programmable or manual operation with press-key controls

and LED digital display. Control offers idle and melt modes, load compensation, filtration tracking and 7-day history.

- Units will include 4 heavy-duty casters, 2 locking.
- Units with filtration system ship with stainless steel **Max** filtration screen and 2 PHT filter envelopes. All units ship with loading, rack, basket handles and choice of fry baskets or wire racks.

Continuing product improvement may subject specifications to change without notice.

Henny Penny Corporation
 PO Box 60 Eaton OH 45320 USA

+1 937 456.8400 800 417.8417
 +1 937 456.8434 Fax 800 417.8434 Fax

www.hennypenny.com

