

PROJECT	QUANTITY	ITEM NO
---------	----------	---------

# Rotisserie Stacked electric



MODEL **SCR-16** 16-spit



Stacked 16-spit rotisserie, model SCR-16

### General Information

Henny Penny rotisseries are known for turning out full loads of consistently delicious rotisserie items day after day, all day long.

What makes Henny Penny different? You'll get *more* of those delicious whole birds, ribs, pork roasts and other center-of-the plate items every day because the Henny Penny rotisserie simply cooks faster. Patented THERMA-VEC® Even Heat Process combines cross-flow convection cooking with radiant heat. The result is thorough, even cooking with uniform browning in a lot less time than other rotisseries.

The stacked SCR-16 is comprised of two SCR-8 six-spit units that operate independently and can cook a whopping 80 whole birds in a single load! With nine individual cooking programs available for each

cabinet, you also have the ability to cook a wide range of food—up to 18 different menu items at the touch of a button. What's more, the sophisticated yet easy-to-use controls let you choose the level of browning you want! Now you can give seasoned and marinated meats, fish and poultry just the right color and crispness that brings customers back for more.

Henny Penny offers a host of rotisserie accessories including spits, cooking baskets, mobile loading stands and more. Spits, rotor disks, drive tube and drip trays are easily removed for cleaning and are available with coated surface.

Stacked rotisseries ship as separate units and include a stacking kit for easy assembly.

### Standard Features

- High quality stainless steel construction, exterior and interior.
- THERMA-VEC® Even Heat Process cooks full loads quickly and evenly:
  - Gentle, cross-flow convection for even cooking throughout cabinet.
  - Radiant heat for uniform browning and crisp texture.
- Digital electronic controls with 9 programmable cook cycles for each cabinet, 18 total.
- Programmable browning and texture control.
- Large LED display for simultaneous time and temperature.
- Food temperature probe.
- Spit rotation switch for easy loading.
- Tempered clear glass doors with black matrix shaded borders.
- Auto-stop rotation when doors open.
- Interchangeable spits, racks and baskets.
- Simple three-piece drive tube and rotor assembly.
- Drive assembly, drip trays and drain pans are easily disassembled for quick clean up.
- Easy-to-clean coated parts available for additional charge.

### Options

- Curved tempered glass outer door, customer side
- Lamp guards
- Coated spits

### Choose standard configuration

- (16) angled spits OR
- (16) piercing spits OR
- (16) solid bottom baskets OR
- (16) wire baskets
- Cabinet:  Solid back  Pass-through (If pass-through)
  - Customer-side door handle
    - with  without
  - Customer-side rotation switch
    - with  without
  - Control side door glass
    - Clear with black matrix shading
    - Mirrored with black matrix shading
  - Mobility
    - (4) 3-inch (76 mm) casters
    - Low profile caster mounting
    - Adjustable leveling legs

Each cabinet must configured identically. Stacking Kit #02665 provided.

<input type="checkbox"/> APPROVED	<input type="checkbox"/> APPROVED AS NOTED	<input type="checkbox"/> RESUBMIT
AUTHORIZED SIGNATURE		DATE



Henny Penny Corporation  
 PO Box 60 Eaton OH 45320 USA  
 +1 937 456.8400 800 417.8417  
 +1 937 456.8434 Fax 800 417.8434 Fax  
[www.hennypenny.com](http://www.hennypenny.com)

# Rotisserie

## Stacked electric

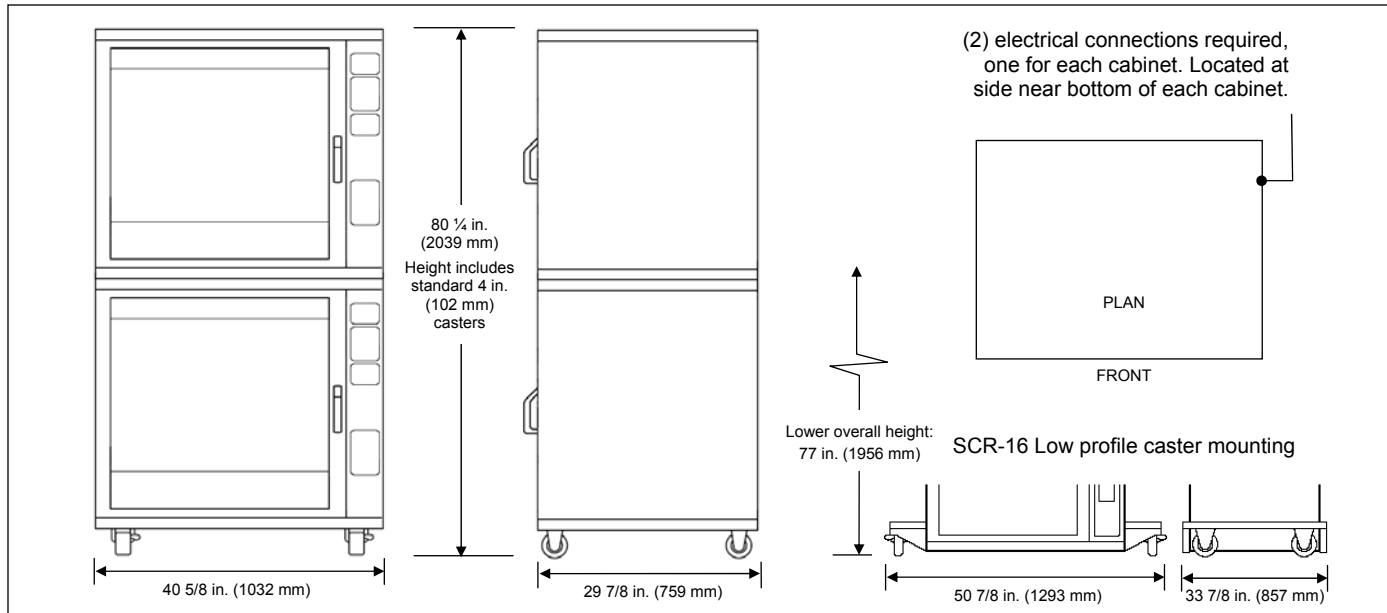
MODEL **SCR-16** 16-spit

### Dimensions

Height: 80 ¼ in. (2039 mm)  
 Width: 40 5/8 in. (1032 mm)  
 Depth: 29 7/8 in. (759 mm)

### Required clearances:

Left: 2 in. (50 mm) air flow  
 Right: 20 in. (500 mm) service access, power cord  
 Back: 32 in. (813 mm) door open  
 Front: 32 in. (813 mm) door open

### Crated dimensions: (2) crates

Length: 48 in. (1219 mm)  
 Depth: 37 in. (940 mm)  
 Height: 48 in. (1219 mm)  
 Volume: 49.3 cu. ft. (1.40 m<sup>3</sup>)

### Net weight

N/A

**Crated weight:** 942 lbs. (428 kg)

**Water connections:** N/A

**Heating:** Electric convection and radiant heat

**Lighting:** (8) 150W tungsten halogen lamps

**Capacity:** 2 ½ lbs. (1.1 kg) whole birds  
 Angled spits 64 whole birds, 4 per spit  
 Piercing spits 80 whole birds, 5 per spit  
 Basket 64 whole birds, 4 per spit

### Electrical

Each cabinet wired separately. Specifications below are per cabinet.

Volts	Phase	Cycle/Hz	Watts	Amps	Wire	Plug
208	1	50/60	11100	50.5	2+G	N/A
240	1	50/60	11100	46.0	2+G	N/A
208	3	50/60	11100	33.6	3+G	NEMA 15-50P 
240	3	50/60	11100	29.1	3+G	
400	3	50	11100	19.3	3NG	N/A

### Laboratory certifications



### Bidding Specifications

- Provide Henny Penny model SCR-16 twelve-spit stacked electric rotisserie. Stacked units are comprised of (2) SCR-8 rotisseries joined with stacking kit.
- Units shall be constructed of high-quality stainless steel interior and exterior, with tempered door glass.
- Units shall feature patented Therma-Vec Even Heat Process that combines cross-flow convection heat with radiant heat for

fast, even cooking and browning.

- Units are programmable and feature large LED displays for time and temperature.
- 2 food probes and probe cooking capability is standard.
- Units shall provide customer-controlled browning levels that can be entered as part of a cooking program.
- Choice of solid back or pass-through (2 doors) design.
- Choice of handle, curved outer door glass

and rotation switch for customer side and control side.

- Choice of (16) angled or piercing spits, or baskets is standard.
- Spits, rotor disks, drive tube and drip trays are removable and are available coated.
- Choice of (4) 3 in. (76 mm) casters, low profile casters, or leveling legs, standard.
- Power cord and plug are shipped with 3-phase units, USA and Canada destinations.

Continuing product improvement may subject specifications to change without notice.

**HENNY PENNY**  
 Global Foodservice Solutions

[www.hennypenny.com](http://www.hennypenny.com)