

PROJECT	QUANTITY	ITEM NO
---------	----------	---------

FlexFusion™ combi oven

Gold Series

FGE 215 Electric
FGG 215 Gas
FlexiRack®



Henny Penny FlexFusion combi ovens combine different cooking methods into one piece of equipment with the flexibility to cook nearly everything on your menu.

The FlexFusion combi incorporates a powerful energy-efficient boilerless steam generation system that quickly adds the precise amount of moisture needed to maintain desired cooking conditions... all without the deliming and maintenance of a boiler.

The Gold Series incorporates many high-end features, such as a 316 stainless steel interior, double-pane door glass, and WaveClean® self-cleaning system.

A simplified control interface offers humidity control, programmability and multi-step cooking. Core temperature probe and USB port are standard.

Roll-in oven rack with tilt-resistant crosswise rails accepts full-size steam table pans or FlexiRack pans and grids that offer additional capacity.

Four cooking modes:

- **Steaming**—Moist heat
86-266°F (30-130°C)
Low and high temperature steaming
- **Convection cooking**—Dry heat
86-572°F (30-300°C) electric
86-482°F (30-250°C) gas
- **Combination**—Dry + moist heat
86-482°F (30-250°C)
- **Rethermalizing**—Dry + moist heat
86-356°F (30-180°C)



Standard Features

- Simple controls with choice of function and digital display for:
 - Cook time
 - Humidity
 - Cabinet temperature
 - Core temperature
- Ready to Cook button
- ClimaSelect control maintains humidity level at 25% increments
- Create and store up to 50 custom cooking programs with up to 5 steps each
- Probe cooking with single-sensor probe
- Temperature in °F or °C
- DynaSteam2 precision boilerless steam generation with built-in energy-saving heat transfer
- 20-level roll-in mobile oven rack with tilt-resistant rails
- Crosswise pan racking for better ergonomics
- 5-speed auto-reverse fan for fast, even cooking throughout the cabinet
- Powerful high-efficiency motor uses up to 15% less energy
- Full perimeter door seal
- Energy efficient double-pane glass Improved WaveClean® self-cleaning system uses 36% less water
- Retractable spray hose for quick, easy rinsing of interior
- Stainless steel interior cabinet with coved corners
- 1 mm stainless steel exterior
- USB port for convenient download of programs, diagnostic messages or HACCP data

Options, accessories*

- Two-in-one cleaning cartridges
- Chicken grids
- Additional mobile oven racks

*See separate accessories data sheets for details

<input type="checkbox"/> APPROVED	<input type="checkbox"/> APPROVED AS NOTED	<input type="checkbox"/> RESUBMIT
AUTHORIZED SIGNATURE		DATE



PROJECT

ITEM NO

FlexFusion™ combi oven

Gold Series

FGE 215 Electric
FGG 215 Gas
FlexiRack®

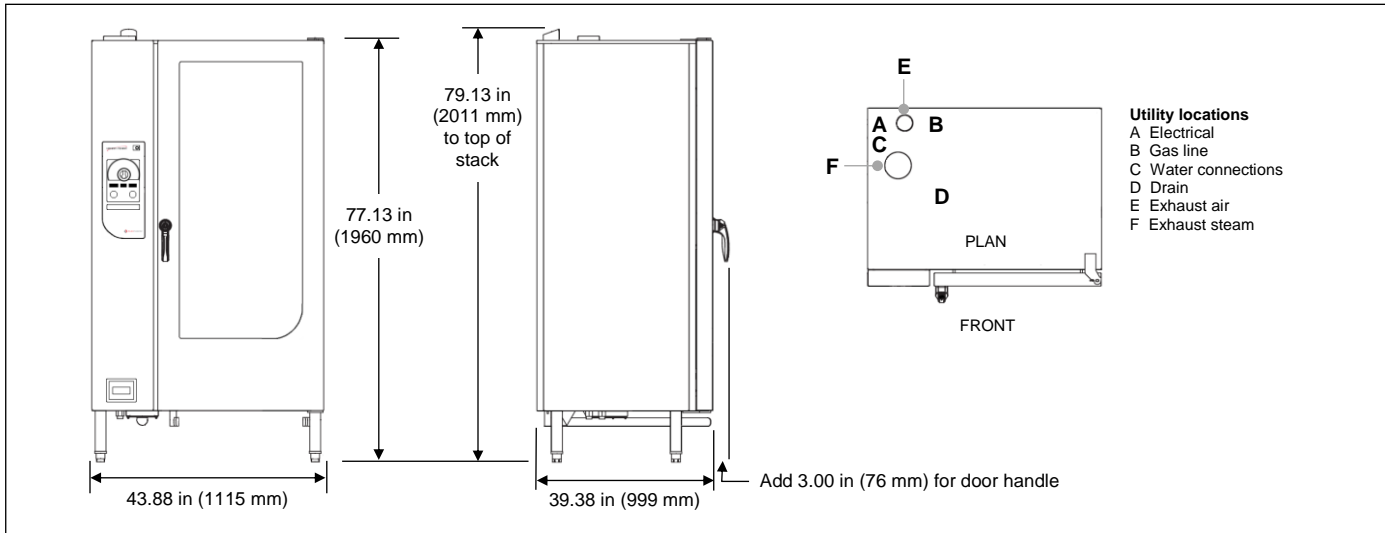

Dimensions

Height	77.13 in (1960 mm)	electric
	79.13 in (2011 mm)	top of stack
Width	43.88 in (1115 mm)	
Depth	39.38 in (999 mm)	

Crated

Length	53 in (1340 mm)
Depth	48 in (1210 mm)
Height	87 in (2200 mm)
Volume	128 ft ³ (3.57 m ³)
Weight	859 lb (390 kg)

Required clearances

Left	20 in (500 mm)	service access
Right	2 in (50 mm)	air flow
Back	2 in (50 mm)	air flow, utilities
Front	28 in (700 mm)	door open

Heat

Electric	Max temperature 572°F (300°C)
Gas	Natural gas or liquid petroleum
	0.75 in gas line NPT external thread
	123,000 BTU/hr or 36 kW/hr
	Max temperature 482°F (250°C)

Water

0.75 in	standard cold water connection
0.75 in	soft water connection
2.0 in (50 mm)	drain

Capacity

- 20 full-size 2.5 in (65 mm) steam table pans crosswise
- 20 FlexiRack pans and grids
- 6 standard 6-chicken grids crosswise, 36 chickens per load
- 12 half-size FlexiRack 6-chicken grids, 2 per rail, 72 chickens per load

Bidding specifications

Provide Henny Penny FlexFusion Gold Series FGE 215 electric or FGG 215 gas combi oven, designed to cook with steaming/moist heat, convection/dry heat, or a combination of dry and moist heat, and holding up to 20 full-size steam table pans crosswise or 20 FlexiRack pans or grids on roll-in oven rack with tilt-resistant rails.

Unit shall incorporate:

- Boilerless DynaSteam2 Technology with precise humidity generation and heat exchange
- ClimaSelect humidity control in 25% increments
- Variable speed, auto reverse fan that moves air in alternating directions for more even heating
- Automated WaveClean® self-cleaning system
- Seamless stainless steel cooking chamber, full-perimeter door seal and double-pane glass for energy efficiency
- Cabinet exterior 20-gauge stainless steel

Electrical

Volts	Phase	Hertz	kW	Amps	Wire*
208	3	60	31.8	88.3	3+G
240	3	60	42.0	101.4	3+G
400	3	50/60	32.7	47.2	3NG

for gas units

120	1	60	1.0	7.2	1NG
-----	---	----	-----	-----	-----

Laboratory certifications



*Units shipped without power cord and plug must have power cord and plug installed on site by a qualified electrician.

Continuing product improvement may subject specifications to change without notice.

24 Hour Technical Support:
 Henny Penny Technical Service
 800 417.8405
technicalservices@hennypenny.com

Henny Penny Corporation
 PO Box 60 Eaton OH 45320 USA
 +1 937 456.8400 800 417.8417
 +1 937 456.8434 Fax 800 417.8434 Fax
www.hennypenny.com

HENNY PENNY
 Engineered to Last